

## CFX.mkII SERIES

The CFX12.mkII is equipped with 8 mono mic/line channels and 2 stereo line-in channels for a total of 12 channels (the CFX16.mkII has 12 mic/line channels and 2 stereo channels for a total of 16, and the CFX20.mkII has 16 mic/line channels and 2 stereo channels for a total of 20). Beyond that, they share the same feature set, with four subgroup outputs, a stereo main out and a subwoofer out.

Each mono mic/line channel has an input Gain control with 45 dB of gain, a sharp 18 dB/octave, 100 Hz Low Cut filter, a 3-band EQ with sweepable midrange, two Aux sends with pre/post switch and two EFX sends, Pan, Mute, Solo, assign switches, a 60mm fader and a Channel Insert jack for connecting an external processor.

The stereo line-in channels have all the same features as the mic/line channels except no low cut filter, an input Gain control with 40 dB of gain, 4-band fixed frequency EQ, and no insert jack.

There are two stereo EFX returns with EFX Return 2 being combined with the internal EFX EMAC digital effects return. The 32-bit EMAC digital effects processor has 16 individual effects, two parameter controls, and a wide spatial expander.

Other features include phantom power, a stereo tape input and output with input level control, a Break switch to mute everything except the tape input, Phones out, stereo Utility Output, stereo 12-segment LED meters, BNC lamp socket, EFX footswitch jack, TRS and XLR stereo Main Output jacks, and a 75 Hz low-pass Subwoofer XLR Output jack.

With professional sound quality and all the right tools for live performances—the CFX.mkII Series is the obvious choice for small bands, solo performers and anyone who needs a reliable compact mixer.

## APPLICATIONS

Live sound mixing, houses of worship, small-to-medium-sized clubs, gymnasiums, banquet halls, conference rooms, boardrooms, multitrack studio and field recording, and many, many more.



## FEATURES:

- 12-channel, 16-channel, and 20-channel / 4-bus compact mixer designed for live sound
- High-headroom mic preamps with RF rejection
- 32-bit EMAC™ digital effects with 9 reverbs, 4 delays, phaser, chorus, flange; 2 parameter controls + EFX wide spatial expander
- External and internal EFX sends
- EFX to Monitor control
- 9-band stereo graphic equalizer
- Inserts on all mic channels and main mix
- True 4-bus design with direct sub outs and L/R assign
- 2 Pre/Post Aux Sends and internal/external FX level sends on each channel
- 3-band EQ with swept mid (100 Hz to 8 kHz) on mic/line channels
- 4-band EQ on stereo line channels
- Pan, Mute, PFL solo on each channel
- Inserts and 100 Hz low-cut filters on all mic/line channels
- Subwoofer output from built-in 18 dB/oct. 75 Hz crossover
- Ingenious Break switch
- Headphone output with level control
- Tape/CD inputs with level control assignable to Main Mix via Break switch
- Logarithmic taper 60 mm faders
- 48V phantom power
- 12V BNC lamp jack

### ONYX 4-BUS SPECIFICATIONS

#### Frequency Response

(Mic Input to any Output, Gain @ unity)	
+0 dB/-1 dB	32 Hz to 20 kHz

#### Distortion (THD and IMD)

(Mic Input to Main Output @ +4 dBu)	
THD (20 Hz to 20 kHz bandwidth)	<0.05%
SMPTE IMD (7 kHz/60 Hz, 4:1)	<0.05%

#### Noise

Equivalent Input Noise (EIN)	
(150 ohm termination, 20 Hz to 20 kHz bandwidth)	-127 dBu
Residual Output Noise	
Main, Monitor, and Effects Outputs (Channel and Main Mix levels off)	-95 dBu

#### Common Mode Rejection Ratio (CMRR)

Mic Input, unity gain @ 1 kHz	better than -60 dB
-------------------------------	--------------------

#### Attenuation/Crosstalk

Adjacent Inputs or Input to Output @ 1 kHz	-90 dB
Fader off @ 1 kHz	-90 dB
Mute Switch and Break Switch Mute	-80 dB

#### Input Gain Control Range

Mono Channels	
Mic Input	+5 dB to +50 dB
Line Input	-15 dB to +30 dB
Stereo Channels	
Line Input	-20 dB to +20 dB

#### Phantom Power

+48 VDC

#### Equalization

Mono Channel EQ	
High Shelving	±15 dB @ 12 kHz
Mid Peaking	±15 dB sweep 100 Hz-8 kHz
Low Shelving	±15 dB @ 80 Hz
Low Cut Filter	18 dB/octave, -3 dB @ 100 Hz
Stereo Channel EQ	
High Shelving	±15 dB @ 12 kHz
High Mid Peaking	±15 dB @ 3 kHz
Low Mid Peaking	±15 dB @ 400 Hz
Low Shelving	±15 dB @ 80 Hz
Low Cut Filter	18 dB/octave, -3 dB @ 100 Hz
Graphic EQ (9 bands)	
Q = 1.414, ISO octave centers	
±15 dB @ 63, 125, 250, 500, 1k, 2k, 4k, 8k, 16k Hz	

#### Mixer Rated Output

Main, Sub, Aux, and EFX Outs	+4 dBu
Maximum Rated Output @ Main XLR and TRS Outputs	+20 dBu

#### Maximum Input Levels

Mic Input (Gain @ +50 dB)	-28 dBu
Mic Input (Gain @ +6 dB)	+18 dBu
Line Input (Gain @ +30 dB)	-8 dBu
Line Input (Gain @ -15 dB)	+38 dBu
Insert Input, Stereo Line Input, Tape Input, and Effects Return	+20 dBu

#### Maximum Voltage Gain

Mic Input to	
Insert Out	50 dB
Tape Out	66 dB
Sub Out	66 dB
Main Out	76 dB
Aux Send	71 dB
Line Input to	
Insert Out	30 dB
Tape Out	46 dB
Sub Out	46 dB
Main Out	56 dB
Aux Send	51 dB
Stereo Line Input to	
Tape Out	40 dB
Sub Out	40 dB
Main Out	50 dB
Aux Send	45 dB
Tape Input to	
Main Out	30 dB
Effects Return to	
Main Out	30 dB

#### Input Impedance

Mic Input	3 kohms, balanced
Line Input	40 kohms, balanced
Insert Input, Stereo Line Input, Tape Input, and Effects Returns	10 kohms, unbalanced

#### Output Impedance

Main Output, Insert Output, Tape Output, Sub Output, and Effects Sends	150 ohms
--	----------

#### Digital Effects

Resolution	32-bit (16-bit, 2-channel)
Number of Presets	16

#### Channel Level LED (Sensitivity)

0 LED = 0 dBu (normal operating level)

### VU Meters

Main Left and Right, 12 segments  
Clip, +10, +7, +4, +2, 0 (0 dBu), -2, -4, -7, -10, -20, -30

### Power Consumption

CFX12.mkII	35 watts
CFX16.mkII	40 watts
CFX20.mkII	45 watts

### Physical Properties (packaged product)

CFX12.mkII	
Height	8.0 in / 203 mm
Width	23.0 in / 584 mm
Depth	21.0 in / 533 mm
Shipping Weight	23.0 lb / 10.4 kg
CFX16.mkII	
Height	8.0 in / 203 mm
Width	27.0 in / 686 mm
Depth	21.0 in / 533 mm
Shipping Weight	27.0 lb / 12.2 kg
CFX20.mkII	
Height	8.0 in / 203 mm
Width	31.0 in / 787 mm
Depth	21.0 in / 533 mm
Shipping Weight	30.0 lb / 13.6 kg

### Physical Properties (product)

CFX12.mkII	
Height	5.0 in / 127 mm
Width	18.4 in / 467 mm
Depth	16.0 in / 406 mm
Net Weight	17.8 lb / 8.1 kg
CFX16.mkII	
Height	5.0 in / 127 mm
Width	22.9 in / 582 mm
Depth	16.0 in / 406 mm
Net Weight	21.0 lb / 9.5 kg
CFX20.mkII	
Height	5.0 in / 127 mm
Width	26.8 in / 681 mm
Depth	16.0 in / 406 mm
Net Weight	24.3 lb / 11.0 kg

### Options

Rackmount Kit for CFX12.mkII
Mixer Bag for CFX12.mkII
Mixer Bag for CFX16.mkII
Mixer Bag for CFX20.mkII
Dust Cover for CFX12.mkII
Dust Cover for CFX16.mkII
Dust Cover for CFX20.mkII

### Ordering Information

CFX12.mkII 12-Ch. Compact SR Mixer w/Effects, US	P/N 0014083-00
CFX12.mkII 12-Ch. Compact SR Mixer w/Effects, EU	P/N 0014083-01
CFX12.mkII 12-Ch. Compact SR Mixer w/Effects, JP	P/N 0014083-02
CFX12.mkII 12-Ch. Compact SR Mixer w/Effects, AU	P/N 0014083-04
CFX16.mkII 16-Ch. Compact SR Mixer w/Effects, US	P/N 0014084-00
CFX16.mkII 16-Ch. Compact SR Mixer w/Effects, EU	P/N 0014084-01
CFX16.mkII 16-Ch. Compact SR Mixer w/Effects, JP	P/N 0014084-02
CFX16.mkII 16-Ch. Compact SR Mixer w/Effects, AU	P/N 0014084-04
CFX20.mkII 20-Ch. Compact SR Mixer w/Effects, US	P/N 0014085-00
CFX20.mkII 20-Ch. Compact SR Mixer w/Effects, EU	P/N 0014085-01
CFX20.mkII 20-Ch. Compact SR Mixer w/Effects, JP	P/N 0014085-02
CFX20.mkII 20-Ch. Compact SR Mixer w/Effects, AU	P/N 0014085-04

### CFX.mkII SERIES DIMENSIONS

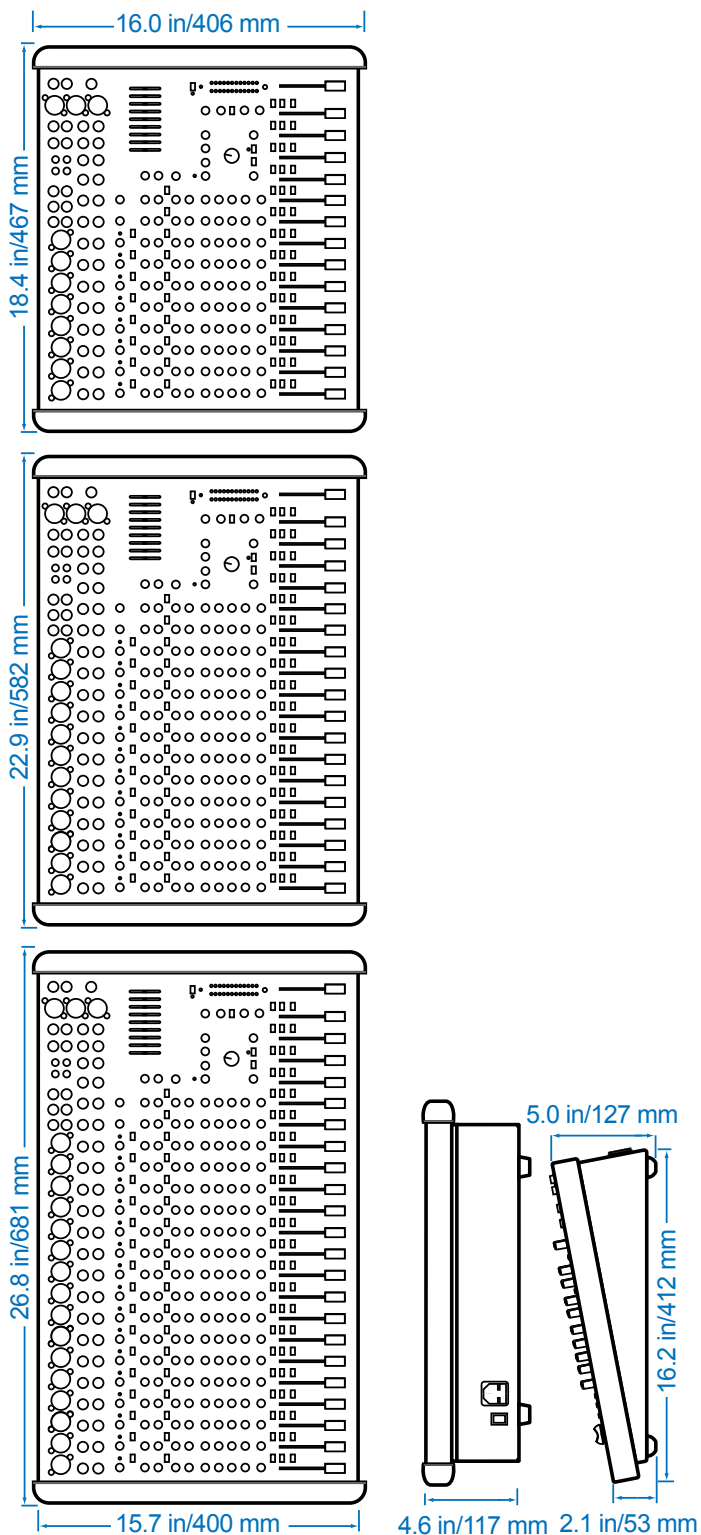

### CFX12.mkII FRONT AND REAR PANELS

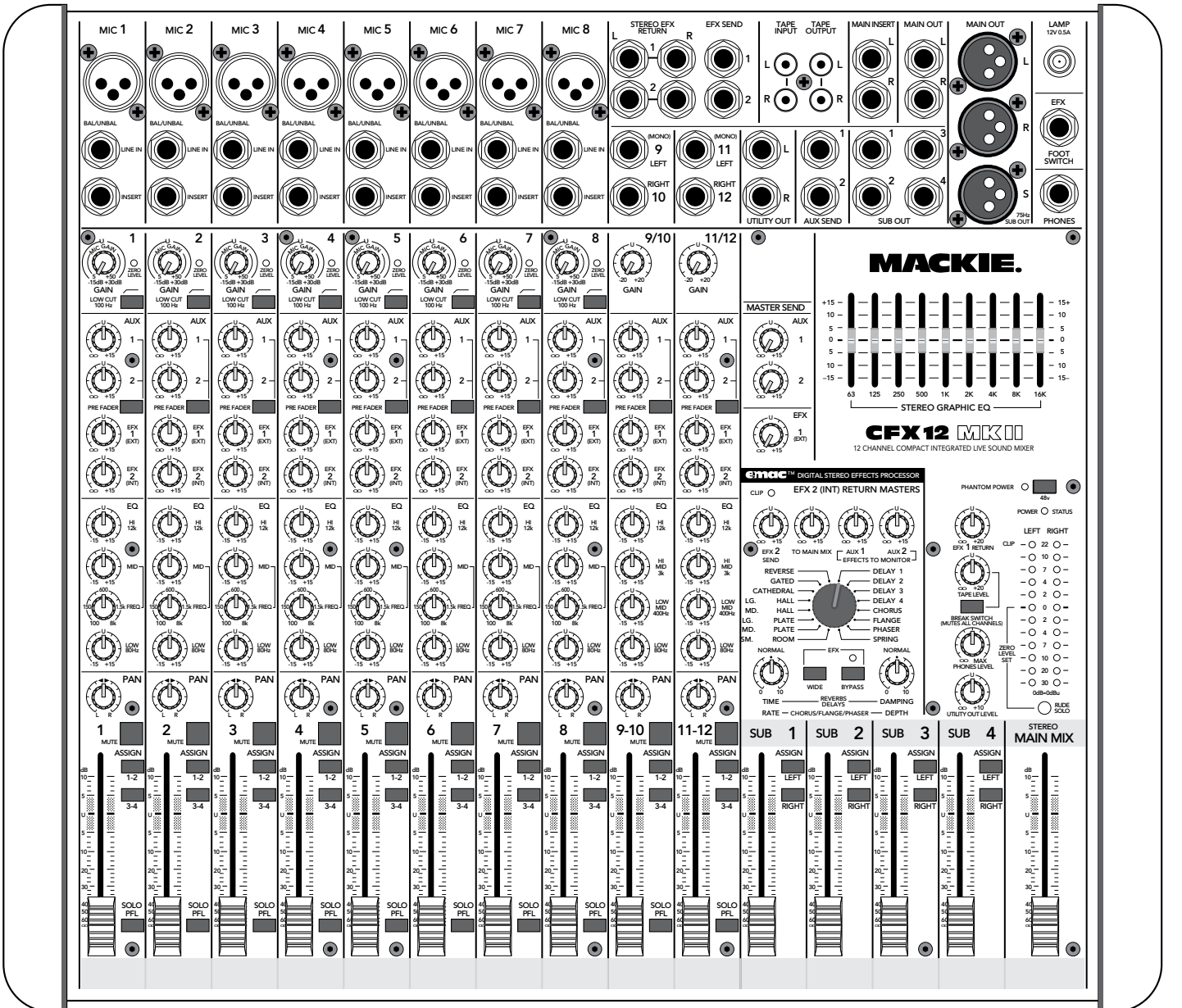
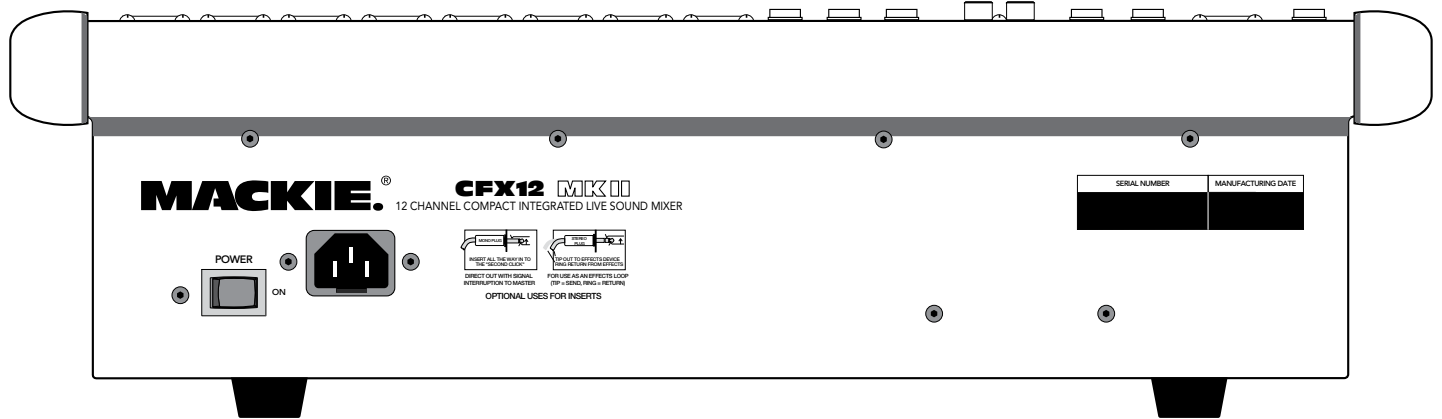

## CFX.mkII BLOCK DIAGRAM

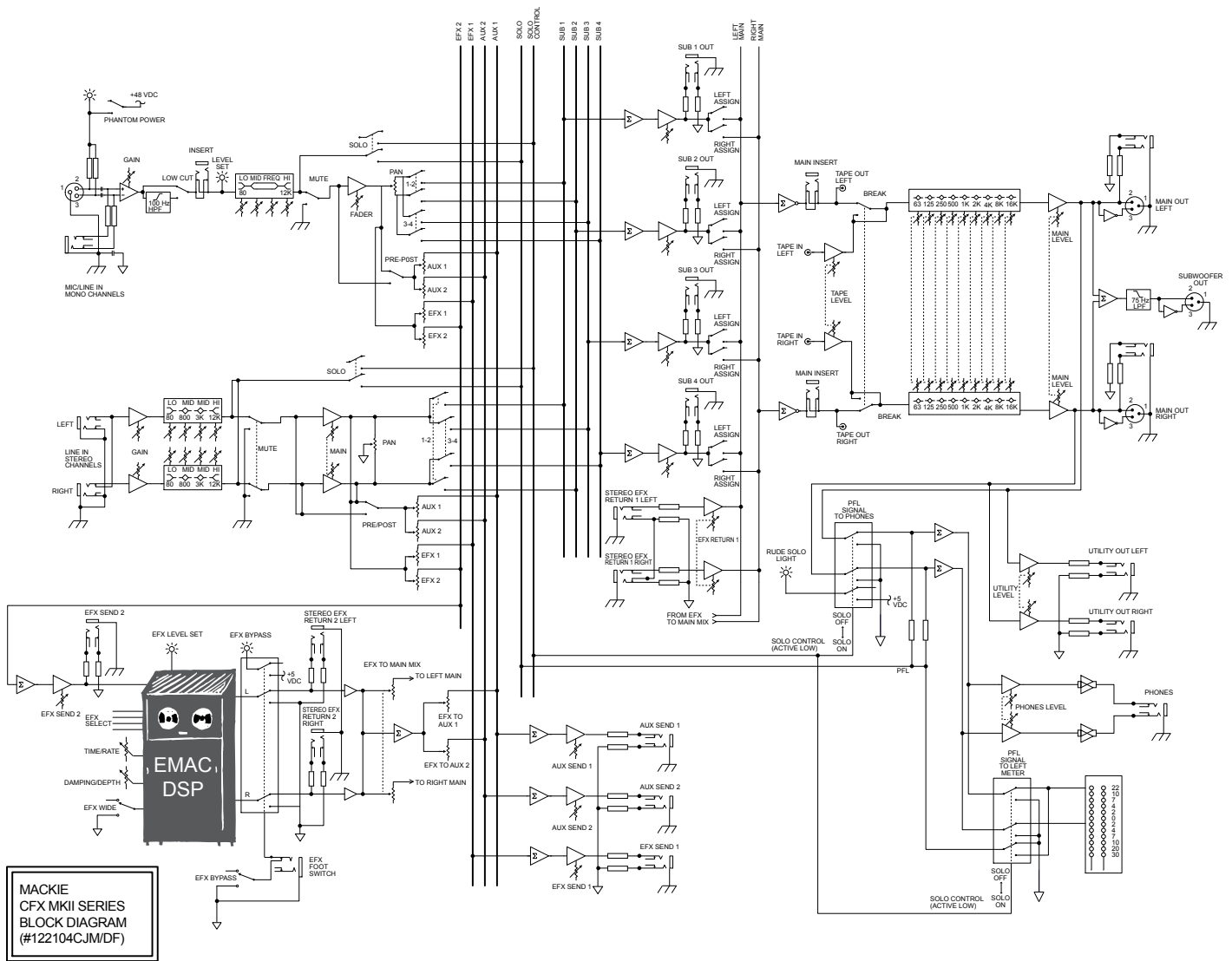

MACKIE  
CFX MKII SERIES  
BLOCK DIAGRAM  
(#122104CJM/DF)

Electronic files for this product are available at:

[www.mackie.com](http://www.mackie.com)

Specification Sheet

CFXmkII\_SS.PDF

Owner's Manual

CFXmkII\_OM.PDF

# MACKIE®

[www.mackie.com](http://www.mackie.com)

16220 Wood-Red Road NE

Woodinville, WA 98072 USA

800-898-3211, Fax 425-487-4337, [sales@mackie.com](mailto:sales@mackie.com)

Part No. SW0776 Rev. A 06/09

Since we are always striving to make our products better by incorporating new and improved materials, components, and manufacturing methods, we reserve the right to change these specifications at any time without notice. "Mackie" and the "Running Man" figure are registered trademarks of LOUD Technologies Inc. All other brand names mentioned are trademarks or registered trademarks of their respective holders, and are hereby acknowledged.

©2009 LOUD Technologies Inc. All Rights Reserved.